

CF500/ CF800

Oil Burner Manual

Beckett[™]
COMMERCIAL PRODUCTS

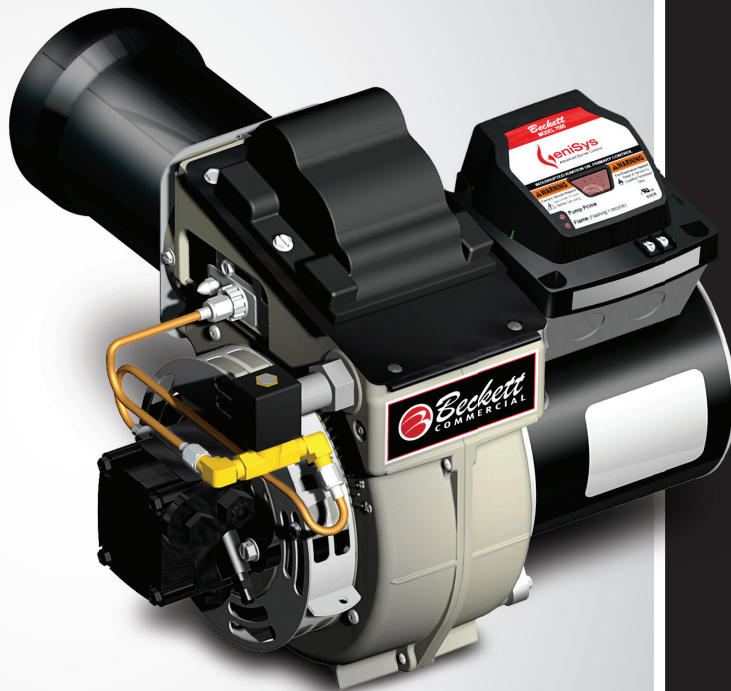

⚠ WARNING

Potential for Fire, Smoke and Asphyxiation Hazards



Incorrect installation, adjustment, or misuse of this burner could result in death, severe personal injury, or substantial property damage.

To the Homeowner or Equipment Owner:

- Please read and carefully follow all instructions provided in this manual regarding your responsibilities in caring for your heating equipment.
- Contact a professional, qualified service agency for installation, start-up or service work.
- Save this manual for future reference.

To the Professional, Qualified Installer or Service Agency:

- Please read and carefully follow all instructions provided in this manual before installing, starting, or servicing this burner or heating system.
- The Installation must be made in accordance with all state and local codes having jurisdiction.

To the Owner:

Thank you for purchasing a Beckett burner for use with your heating appliance. Please pay attention to the Safety Warnings contained within this instruction manual. Keep this manual for your records and provide it to your qualified service agency for use in professionally setting up and maintaining your oil burner.

READ THESE INSTRUCTIONS AND SAVE FOR REFERENCE

Your Beckett burner will provide years of efficient operation if it is professionally installed and maintained by a qualified service technician. If at any time the burner does not appear to be operating properly, **immediately contact your qualified service agency** for consultation.

We recommend annual inspection/ service of your oil heating system by a qualified service agency.

Daily – Check the room in which your burner/appliance is installed. Make sure:

- Air ventilation openings are clean and unobstructed
- Nothing is blocking burner inlet air openings
- No combustible materials are stored near the heating appliance
- There are no signs of oil or water leaking around the burner or appliance

Weekly

- Check your oil tank level. Always keep your oil tank full, especially during the summer, in order to prevent condensation of moisture on the inside surface of the tank.

Contents

General Information	4
Hazard Definitions	4
Agency approvals.....	4
Specifications	4
Owner's Responsibility:.....	5
Professional Installer/Service Agency Responsibility:.....	5
Pre-installation Checklist.....	5
Combustion air supply.....	5
Clearances	5
Fuel supply.....	5
Nozzle Pressure	6
Electrical Supply.....	6
Verify Burner Components	6
Vent System	6
Verify Firing Rate.....	7
Verify air tube	7
Stray Light	8
Dust and Moisture	8
Mount the Burner.....	8
Mount flange(s) on air tube	9
Mount air tube to burner.....	9
Install nozzle	9
Check electrode settings.....	9
Install nozzle line assembly.....	9
Set dimension Z	10
Insert burner	10
Fuel unit by-pass plug.....	10
Oil supply/return lines.....	10
Burner fuel flow	11
Wire the Burner.....	11
Typical Burner Sequence of Operation - 7505 Control.	14
Typical Burner Wiring - 7505 Control	15
Reset Button Operation.....	15
Typical Burner Sequence of Operation - R7184P Control.	16
Prepare the Burner for Start-up	17
Initial air settings (<i>Table 5</i>).....	18
Set appliance limit controls	18
Prepare the fuel unit for air venting.....	18
Start the Burner	19
Starting the burner and venting air.....	19
Disable function.....	19
Cad Cell Resistance Measurement.....	20
Resetting From Restricted or Hard Lockout.....	20
Set combustion using instruments	20
Maintenance and Service.....	21
Replacement parts	22
Limited Warranty Information	24

General Information

Hazard Definitions

DANGER Indicates a hazardous situation, which, if not avoided, will result in death or serious injury.

WARNING Indicates a hazardous situation, which, if not avoided, could result in death or serious injury.

CAUTION Indicates a hazardous situation, which, if not avoided, could result in minor or moderate injury.

Within the boundaries of the hazard warning, there will be information presented describing consequences if the warning is not heeded and instructions on how to avoid the hazard.

NOTICE Intended to bring special attention to information, but not related to personal injury or property damage.

Agency approvals

- UL listed to comply with ANSI/UL296 and certified to CSA B140.0.
- Accepted by N.Y.C. M.E.A.
- Other approvals may be available and must be specified at time of order.



CAUTION **Frozen Plumbing and Water Damage Hazard**

If the residence is unattended in severely cold weather, burner primary control safety lockout, heating system component failures, power outages or other electrical system failures could result in frozen plumbing and water damage in a matter of hours. For protection, take preventive actions such as having a security system installed that operates during power outages, senses low temperature and initiates an effective action. Consult with your heating contractor or a home security agency.

Specifications

Fuels	<p>CAUTION DO NOT USE GASOLINE, CRANKCASE OIL, OR ANY OIL CONTAINING GASOLINE</p> <p>U.S. #1 or #2 Fuel Oil only (ASTM D396) Canada #1 Stove Oil or #2 Furnace Oil only</p>
Firing range	CF500: 1.75 to 5.50 GPH CF800: 3.00 to 8.00 GPH
Motor	1/3 HP 3450 RPM 120/60 hz standard 4.8 amps @ 120 VAC
Igniter	120V/14,000V
Housing	Cast aluminum
Fuel unit	100 - 200 PSIG
Oil nozzle	45° - 70° solid
Shipping weight	55 lbs.

NOTICE **50 Hz Motors** — The burner ratings, air settings and nozzle ratings are based on standard 60 hz motors (at 3450 rpm). Derate all ratings 20% when using 50 hz motors. Consult factory for specific application data.

NOTICE **High Altitude Installations** — Accepted industry practice requires no derate of burner capacity up to 2,000 feet above sea level. For altitudes higher than 2,000 feet, derate burner capacity 2% for each 1000 feet above sea level.

Owner's Responsibility:**WARNING****Follow These Instructions Exactly**

Failure to follow these instructions, misuse, or incorrect adjustment of the burner could lead to equipment malfunction and result in asphyxiation, explosion or fire.

Contact a professional, qualified service agency for the installation, adjustment and service of your oil burning system. Thereafter, have your equipment adjusted and inspected at least annually to ensure reliable operation. This work requires technical training, trade experience, licensing or certification in some states and the proper use of special combustion test instruments.

Please carefully read and comply with the following instructions:

- Never store or use gasoline or other flammable liquids or vapors near this burner or appliance.
- Never attempt to burn garbage or refuse in this appliance.
- Never attempt to light the burner by throwing burning material into the appliance.
- Never attempt to burn any fuel not specified and approved for use in this burner.
- Never restrict the air inlet openings to the burner or the combustion air ventilation openings in the room.

Professional Installer/Service Agency Responsibility:**WARNING****Follow These Instructions Exactly**

Failure to follow these instructions could lead to equipment malfunction and result in asphyxiation, explosion or fire.

- Please read all instructions before proceeding. Follow all instructions completely.
- This equipment must be installed, adjusted and started by a qualified service agency that is experienced with all applicable codes and ordinances and responsible for the installation and commission of the equipment.
- The installation must comply with all local codes and ordinances having jurisdiction and the latest editions of the NFPA 31 and CSA-B139 & B140 in Canada.

Pre-installation Checklist**Combustion air supply****WARNING****Adequate Combustion and Ventilation Air Supply Required**

Failure to provide adequate air supply could seriously affect the burner performance and result in damage to the equipment, asphyxiation, explosion or fire hazards.

- The burner cannot properly burn the fuel if it is not supplied with a reliable combustion air source.
- Follow the guidelines in the latest editions of the NFPA 31 and CSA-B139 regarding providing adequate air for combustion and ventilation.

The burner requires combustion air and ventilation air for reliable operation. Assure that the building and/or combustion air openings comply with National Fire Protection Standard for Oil-Burning Equipment, NFPA 31. For appliance/burner units in confined spaces, the room must have an air opening near the top of the room plus one near the floor, each with a free area at least one square inch per 1,000 Btu/hr input of all fuel burning equipment in the room. For other conditions, refer to NFPA 31 (CSA B1139-M91 in Canada).

If there is a risk of the space being under negative pressure or of exhaust fans or other devices depleting available air for combustion and ventilation, the appliance/burner should be installed in an isolated room provided with outside combustion air.

Clearances

With the burner installed in the appliance, there must be adequate space in front of and on the sides of the burner to allow access and operation. Verify that the clearance dimensions comply with all local codes and with the appliance manufacturer's recommendations.

Fuel supply**CAUTION****Oil Supply Pressure Control Required**

Damage to the pump, filter or other component seals could cause possible oil leakage and potential fire hazard.

- The oil supply inlet pressure to the fuel unit cannot exceed 3 psig.
- Ensure that a pressure-limiting device is installed in accordance with the latest edition of the NFPA 31.

The fuel supply piping and tank must provide #1 or #2 fuel oil at pressure or vacuum conditions suitable for

the fuel unit (oil pump) on the burner. Refer to fuel unit literature in the literature envelope in the burner carton to verify allowable suction pressure.

If fuel supply is **level with or higher than** fuel unit —

When the fuel unit is not required to lift the oil, the installation is usually suitable for either a one-pipe or two-pipe oil system. The oil pressure at the inlet of the fuel unit must not exceed 3 psig. Refer to the *Mount the Burner* Section of this manual for one-pipe or two-pipe fuel supply installation instructions.

If fuel supply is **below** the fuel unit —

Use a two-pipe oil system when the fuel unit must lift the oil more than 8 feet if burner is equipped with a **B** fuel unit. The return line provided by the two-pipe system is needed to purge the air from the fuel lines and minimize the likelihood of air-related problems during operation.

Nozzle Pressure

WARNING Correct Nozzle and Flow Rate Required



Incorrect nozzles and flow rates could result in impaired combustion, under-firing, over-firing, sooting, puff-back of hot gases, smoke and potential fire or asphyxiation hazards.

Use only nozzles having the brand, flow rate (gph), spray angle and pattern specified by the appliance manufacturer. Follow the appliance manufacturer's specifications for the required pump outlet pressure for the nozzle, since this affects the flow rate.

- Nozzle manufacturers calibrate nozzle flow rates at 100 psig.
- This burner utilizes pressures higher than 100 psig, so the actual nozzle flow rate will be greater than the gph stamped on the nozzle body. (Example: A 2.00 gph nozzle at 140 psig = 2.37 gph.
- For typical nozzle flow rates at various pressures see **Table 1**.

The fuel unit nozzle port pressure is factory set at 140 psig. Some original equipment manufacturer burner applications may call for a lower pressure to obtain a required firing rate. Do not change this pressure unless directed to do so by the appliance manufacturer.

Electrical Supply

Verify that the power connections available are correct for the burner. Refer to **Figure 1**. All power must be supplied through fused disconnect switches.

Verify Burner Components

- **Burner**, Model CF500 or CF800
- **Air tube assembly**
- **Mounting flange kit**
- **Oil nozzle**, per **Table 1** — Only 45° to 70° solid pattern nozzles are recommended unless otherwise specified by appliance manufacturer. (See specific appliance recommendation sheet or refer to OEM Spec Guide). Find the required firing rate in the 140 psig column (factory-set fuel unit pressure). Select the corresponding nozzle from column 1 (**Rated gph @ 100 psig**).

Vent System

Table 1 - Nozzle Capacities

Rated gph @ 100 psig	Pressure - Pounds per square inch	
	140	150
1.75	2.07	2.14
2.00	2.37	2.45
2.25	2.66	2.74
2.50	2.96	3.06
2.75	3.24	3.37
3.00	3.55	3.68
3.50	4.13	4.29
4.00	4.70	4.90
4.50	5.30	5.51
5.00	5.90	6.13
5.50	6.50	6.74
6.00	7.10	7.33
6.50	7.65	7.96

The flue gas venting system must be in good condition and must comply with all applicable codes.

Figure 1. Typical Nameplate

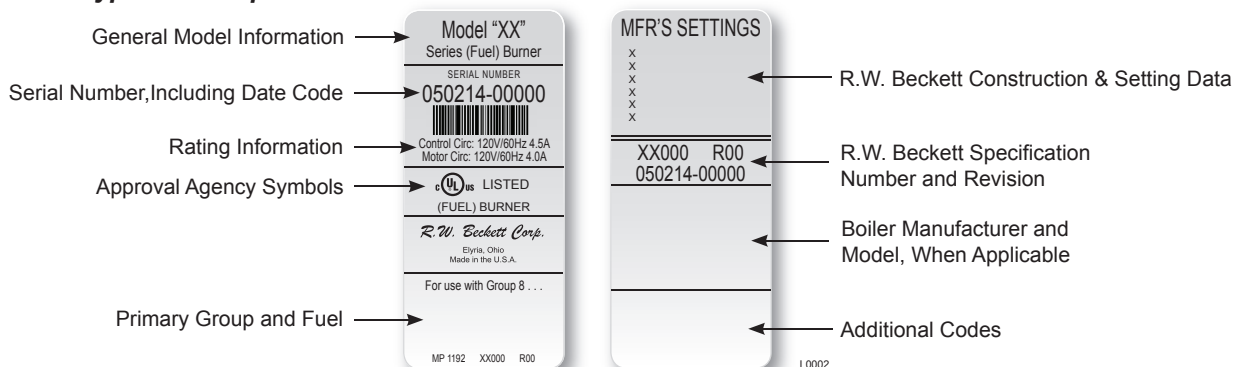

Inspect Chimney or Direct Vent System



Fire, Smoke & Asphyxiation Hazard

- Carefully inspect the chimney or exhaust vent system.
- Make sure it is properly sized and in good working condition.
- Follow the instructions supplied by the appliance manufacturer.
- The installation must strictly comply with all applicable codes, authorities having jurisdiction and the latest revision of the National Fire Protection Association Standard NFPA 31 for the installation of chimneys and vent sizing, (or CSA-B139 and CSA-B140 in Canada).
- Regulation by these authorities take precedence over the general instructions provided in this manual.

1. Starting with minimum gph firing rate, the minimum size recommended is 8" flue pipe with 8" X 8" inside chimney, unless specified otherwise by the appliance manufacturer.
2. A chimney flue shall extend at least 3 feet above the highest point at which the chimney comes in contact with the roof, and not less than 2 feet above the highest roof surface or structure within 10 feet horizontally of the chimney. Refer to **Figure 2**.
3. Any accumulation of soot or debris in chimney offsets should be removed
4. Any obstructions such as a protruding joint or a piece of broken tile wedged in the chimney should be removed.
5. No other appliance connection should be made to the same flue pipe.
6. The flue pipe should have an upward pitch toward the chimney of at least 1/4" per foot of length. It should fit tightly and should not project into the chimney.
7. Any leakage between tiles, around clean-out doors, or around the vent pipe should be sealed.

INSULATED STAINLESS STEEL CHIMNEY LINERS

The new designs of high efficiency oil furnaces and boilers in conjunction with flame retention oil burners are more efficient. One result of increased efficiency is lower flue gas temperatures. As flue gases rise in the chimney, they will cool and condense when they reach the dew point. The condensation will mix with the sulphur in the flue gases creating sulphuric acid. The acid will attack the chimney mortar, brick and clay liners causing corrosion, deterioration and blockage of the chimney. Eventually the blockage could prevent exhausting the flue gases. Instead, the flue gases could vent out the barometric damper into the living space.

Therefore, it is strongly recommended that an approved insulated stainless steel liner be installed.

Verify Firing Rate

Refer to appliance manufacturer's instructions (if available) for firing rate and nozzle selection. Otherwise, the maximum recommended firing rate for the burner depends on the length of the firing chamber and the distance from the burner center to the chamber floor. Verify that the chamber dimensions are at least as large as the minimum values given in **Figure 2**. If the appliance dimensions are smaller than recommended, reduce the firing rate accordingly.

Figure 2. - Dimensions: Minimum Combustion Chamber and Air Tube Mounting.

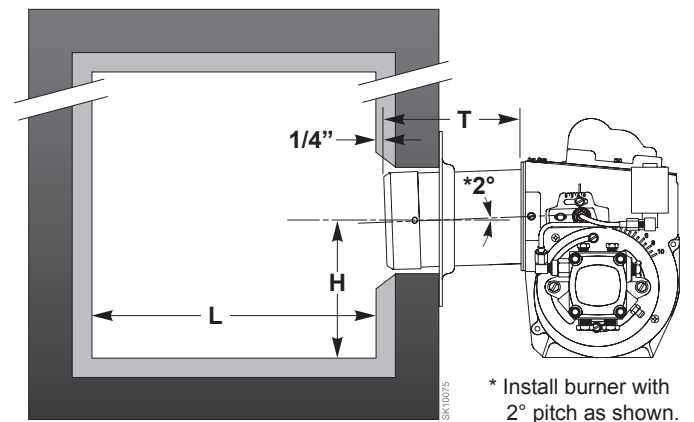

Firing Rate	Minimum Dimensions			
	(with damper)		(without damper)	
	H	L	H	L
1.75 to 3.00 gph	7.5"	18.0"	8.0"	19.0"
4.00 gph	8.0"	21.0"	9.5"	23.0"
5.00 gph	9.0"	23.0"	10.5"	30.0"
6.00 gph	10.0"	28.0"	11.5"	40.0"
7.00 gph	11.0"	34.0"	12.0"	46.0"
8.00 gph	14.0"	38.0"	14.0"	51.0"

Air Tube Length (Dimension T)	A.T.C. Codes (A.T.C. = Air Tube Combination)		
	CF500	CF800	
		Tube A	Tube B
6.00"	CF 60 KK	CF 60 KH	CF 60 KJ
8.00"	CF 80 KK	CF 80 KH	CF 80 KJ
10.00"	CF 100 KK	CF 100 KH	CF 100 KJ
14.00"	CF 140 KK	CF 140 KH	CF 140 KJ
16.00"	CF160 KK	--	--
17.00"	--	CF 170 KH	CF 170 KJ

Verify air tube

The information in this section may be disregarded if the air tube is supplied by the appliance manufacturer.

Two tube arrangements are available –

- CF500 1.75 to 5.50 GPH
- CF800 Tube **A** — 3.00 to 7.00 GPH
Tube **B** — 5.00 to 8.00 GPH

Maximum firing capacity depends on the firebox pressure. Use **Table 2** to verify the correct air tube type for the firing rate required. Use Tube **B** only when Tube **A** cannot provide the firing rate required.

See **Figure 2** to verify the correct air tube length and air tube combination code.

Table 2 - Air tube capacities vs firebox pressure

Firebox pressure (in w.c.)	CF500		CF800		CF500		CF800	
	Tube KK	Tube KH	Tube KJ	Tube KK	Tube KH	Tube KJ	Tube KK	Tube KJ
	No reserve air				10% Turndown			
0.0"	5.50	7.00	8.00	4.95	6.30	7.20		
0.1"	4.75	6.25	7.50	4.27	5.62	6.75		
0.2"	4.00	5.50	6.75	3.60	4.95	6.07		
0.3"	3.50	4.50	6.25	3.15	4.00	5.62		
0.4"	2.75	3.75	5.50	2.47	3.37	4.95		
0.5"	2.00	3.00	5.00	1.80	2.70	4.50		

Note: The above ratings may vary 5% due to variations in actual job conditions.

Figure 3a - Firebox Pressure: CF500 with no Reserve Air

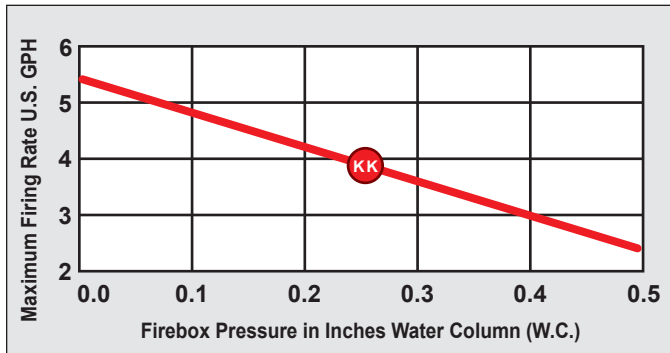
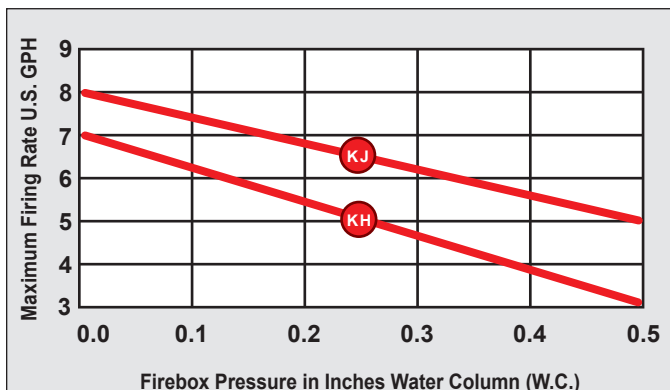

Figure 3b - Firebox Pressure: CF800 with no Reserve Air



Stray Light

CAUTION Protect Against Stray Light Lockout

Failure to follow these instructions could cause loss of burner operation resulting in no heat, an unplanned process interruption, work stoppage and the potential for frozen plumbing or other cold weather property damage.

- The control must detect a dark, no-flame condition in order to start the burner or it will hold in the stray light lockout mode.
- Shield the burner from direct exposure to intense light.

Dust and Moisture

WARNING Protect Against Dust and Moisture

Wet, dusty environments could lead to blocked air passages, corrosion damage to components, impaired combustion performance and result in asphyxiation, explosion or fire.

- This burner is designed for clean, dry installations.
- Electrical controls are not protected against rain or sprayed water.
- Keep the installation clear of dust, dirt, corrosive vapors, and moisture.
- Protective covers and more frequent maintenance may be required.

Mount the Burner

CAUTION Protect the Air Tube From Overheating

Overheating could cause damage to the air tube and other combustion components leading to equipment malfunction and impaired combustion performance.

- The end of the air tube must not extend into the combustion chamber unprotected unless it has been factory-tested and specified by the appliance manufacturer.
- Position the end of the air tube ¼" back from flush with the refractory inside entry wall to prevent damage from overheating.

Mount flange(s) on air tube

This section does not apply to burners with welded flanges.

1. Do not install air tube on burner.
2. For *non-pressure firing flange*, refer to **Figure 4**: Install gasket (item **a**) and flange (item **d**). Ignore the next paragraph.
3. For *pressure-firing flange*, refer to **Figure 4**: Slide gasket (item **a**) onto the air tube, making sure the top of the air tube is up. Pre-drill holes in the pressure firing plate (item **b**) to match the appliance studs. Slide the pressure firing plate (item **b**) and flange (item **d**) onto the air tube as shown. Wrap ceramic fiber rope (item **c**) around the air tube and press tightly into the inside diameter of the flange (item **d**).
4. Slide the air tube (item **e**) into position in the appliance front. Tighten the flange-mounting-stud nuts. Set the insertion of the air tube so dimension **G** is 1/4" nominal.
5. Pitch the air tube at 2° from horizontal as shown and secure the flange to the air tube.

Figure 4 - Mount flange(s) on air tube

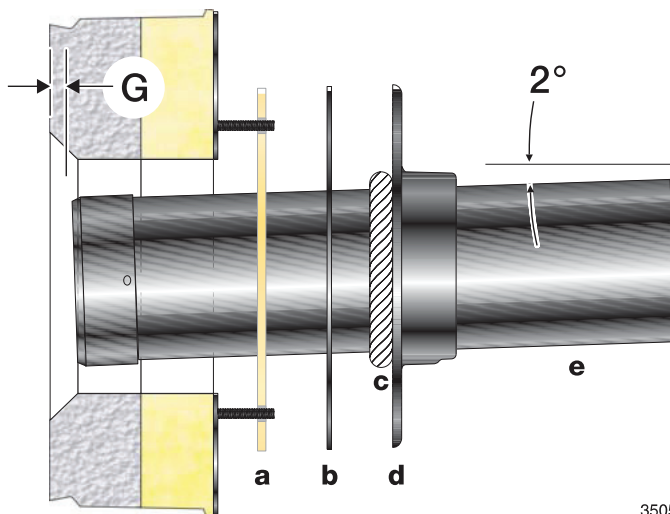

3505

Mount air tube to burner

Insert the air tube into the burner housing. Carefully align the the four screw holes.

Attach the air tube to the burner using the four provided screws.

Install nozzle

Install the oil nozzle in the nozzle adapter. Use a 3/4" open-end wrench to steady the nozzle adapter and a 5/8" open-end wrench to turn the nozzle. Tighten securely but do not over-tighten.

Check electrode settings

WARNING Maintain Electrode Specifications

Failure to properly maintain these specifications could cause ignition malfunction, puff-back of hot gases, heavy smoke, asphyxiation, explosion and fire hazards.

Adjust the electrode gap and position in relation to the nozzle to the following specifications.

Check, and adjust if necessary, the critical dimensions shown in **Figure 5**. Verify that the oil tube assembly and electrodes are in good condition, with no cracks or damage.

Figure 5 - Nozzle and nozzle line assembly

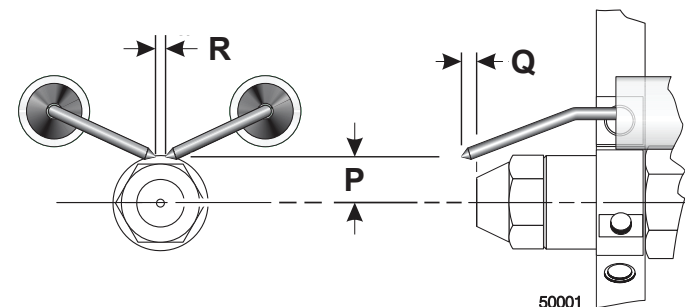

Legend (Figure 5)

- P Nozzle centerline to electrode tip = 3/16"
- Q Nozzle face to electrode tip = 1/4"
- R Electrode spacing = 3/16" gap

Install nozzle line assembly

Insert the nozzle line assembly into the burner air tube. Reference **Figure 6**.

Slide the secondary adjusting plate (**Figure 7**, item **f**) completely to the left on the indicator adjusting plate (item **e**). Finger tighten acorn nut (item **c**) to secure the two plates together. Slide both plates completely to the right (Indicator Plate will read 0). Tighten fastener (item **d**). Install the spline nut on the end of the nozzle line, leaving the nut loosely placed so the plates can be moved.

Figure 6 - Nozzle line assembly in burner

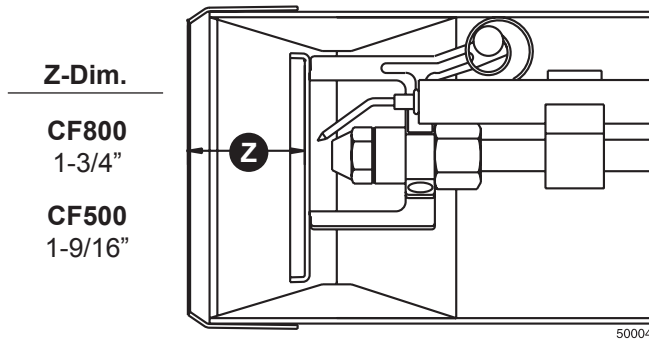
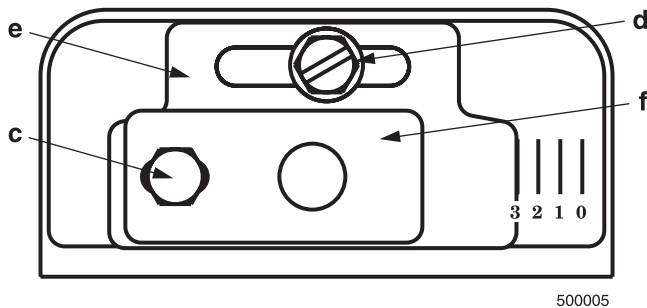

Figure 7 - Adjusting plate assy.



Legend (Figures 7)

- c Bottom acorn nut
- d Fastener
- e Indicator adjusting plate
- f Secondary adjusting plate

Set dimension Z

- o Loosen fastener c in **Figure 7**. Slide the nozzle line and plate assembly until dimension **Z** in **Figure 6** is:
 CF500 - 1-9/16" ±1/16"
 CF800 - 1-3/4" ±1/16"
- o When dimension Z (from end of air tube to flat area of front face of head) is correctly set, tighten acorn nut (item c).
- o Attach the oil line from the oil valve to the nozzle line end. Tighten securely.
- o Before proceeding, check dimension **Z** once again. Loosen acorn nut **c** if necessary to reposition the nozzle line. Once dimension **Z** is set, **do not loosen the acorn nut (item) c again**. Note that for the setting of fastener **d**, refer to the initial head position procedure under "Start-up Checklist" section (Pg.18).

Insert burner

- o Position the burner in the front of the appliance and loosely tighten the nuts on the mounting studs. The burner should be pitched downward 2° as shown in **Figure 4**.
- o Secure the burner to the appliance by tightening the nuts on the burner flange mounting studs.

Fuel unit by-pass plug

WARNING Do Not Install By-pass Plug with 1-Pipe System

Failure to comply could cause immediate pump seal failure, pressurized oil leakage and the potential for a fire and injury hazard.

- o The burner is shipped without the by-pass plug installed.
- o Intall the by-pass plug in two-pipe oil supply systems ONLY.

- o The CF500 and CF800 burners are shipped without the by-pass plug installed in the fuel line.
- o The by-pass plug must NOT be installed when using with a one-pipe oil system.
- o The by-pass plug MUST be installed when using a two-pipe oil system.

Oil supply/return lines

WARNING Install Oil Supply To Specifications



Failure to properly install the oil supply system could cause oil leakage, equipment malfunction, puff-back of hot gases, heavy smoke, asphyxiation, explosion and fire hazards.

- o Carefully install the oil supply lines, fittings and components using the guidelines provided in this section.
- o The oil supply must comply with the latest edition of NFPA 31 (Canada CSA B139) and all applicable codes.
- o Do NOT install valves in return lines.
- o If the oil supply inlet pressure to the pump exceeds 3 psig or for gravity feed systems, install an oil safety or pressure reducing valve (Webster OSV, Suntec PRV or equivalent).
- o Install the oil tank and oil lines in accordance with all applicable state and local codes.
- o Size the oil supply and return lines using the guidelines given in the fuel unit literature included in the literature envelope. Oil line flow rate will equal the burner rate for one-pipe systems. For two-pipe systems, refer to **Table 3** for the fuel unit gear set capacity - the rate at which fuel is recirculated when connected to a two-pipe system. However, size two-pipe oil lines based on this flow rate.
- o Use continuous lengths of heavy-wall copper tubing, routed under the floor where possible. Do not attach fuel lines to the appliance or to floor joists if possible. This will reduce vibration and noise transmission problems.

- Install an oil filter sized to handle the fuel unit gearset flow capacity (**Table 3**) for **two-pipe systems**. Size the filter for the firing rate for **one-pipe systems**. Locate the filter immediately adjacent to the burner fuel unit.
- Install two high-quality shut-off valves in accessible locations on the oil supply line. Locate one valve close to the tank. Locate the other valve close to the burner, upstream of the fuel filter.

Table 3. Fuel Unit gearset capacity

Fuel unit model number	Gearset capacity (GPH)
A2VA-7116	17
A2YA-7916	20
B2VA-8216	21
B2YA-8916	25
B2TA-8248	21

Burner fuel flow

- **One-pipe systems** – See **Figure 8** for the fuel flow path.
Figure 8 is based on type **B** fuel unit.
Oil supply connects to one of the fuel unit inlet ports.
- **Two-pipe systems** – See **Figure 9** for the fuel flow paths for two-pipe oil systems.
Figure 9 is based on type **B** fuel unit .
Oil supply connects to one of the fuel unit inlet ports. Oil return connects to the fuel unit return port.
(Install the by-pass plug in the fuel unit for two-pipe systems.)

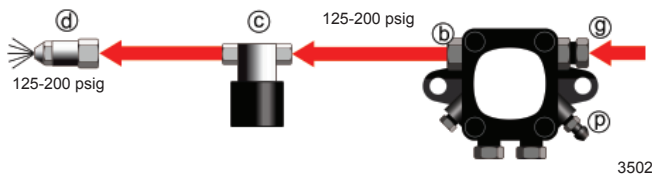
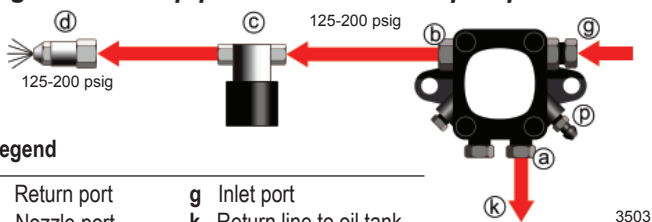
Figure 8 - One-pipe oil flow with “B” pump**Figure 9 - Two-pipe oil flow with “B” pump**

Legend

- | | |
|--------------------|---------------------------|
| a Return port | g Inlet port |
| b Nozzle port | k Return line to oil tank |
| c Oil valve | p Air bleed valve |
| d Nozzle & adapter | |

Nozzle pressure – The fuel unit nozzle port pressure is factory set at 140 psig. Some original equipment manufacturer burner applications may call for a lower pressure to obtain a required firing rate. Do not change this pressure unless directed to do so by the appliance manufacturer.

Wire the Burner

WARNING Electrical Shock Hazard

Electrical shock can cause severe personal injury or death.

- Disconnect electrical power before installing or servicing the burner.
 - Provide ground wiring to the burner, metal control enclosures and accessories. (This may also be required to aid proper control system operation)
 - Perform all wiring in compliance with the National Electric Code ANSI/NFPA 70 (Canada CSA C22.1).
- Install the burner and all wiring in accordance with the National Electrical Code and all applicable local codes or requirements. In Canada, comply with the Canadian Electrical Code, Part 1.
 - Wire the burner in compliance with all instructions provided by the appliance manufacturer. Verify operation of all controls in accordance with the appliance manufacturer's guidelines.
 - See **Figure 10** for a typical wiring diagram with the 7505 oil primary, for reference purposes only. See **Figure 12** for a typical wiring diagram with the R7184 oil primary, for reference purposes only.
 - The 7505 primary control with valve-on delay (pre-time) and burner motor-off delay (post time) requires a constant 120 volts AC power source supplied to the BLACK wire on the control. The RED wire goes to the appliance limit circuit. Please note that other control manufacturers may use different wire colors for power and limit connections.

CAUTION Incorrect Wiring Will Result in Improper Control Operation

- GeniSys wiring label colors may not match the wire colors of the burner or other manufacturers' controls.
- The GeniSys Control should be wired according to the appliance manufacturer's instructions.

Figure 10. – Typical Wiring (7505P)

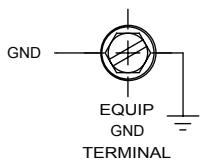
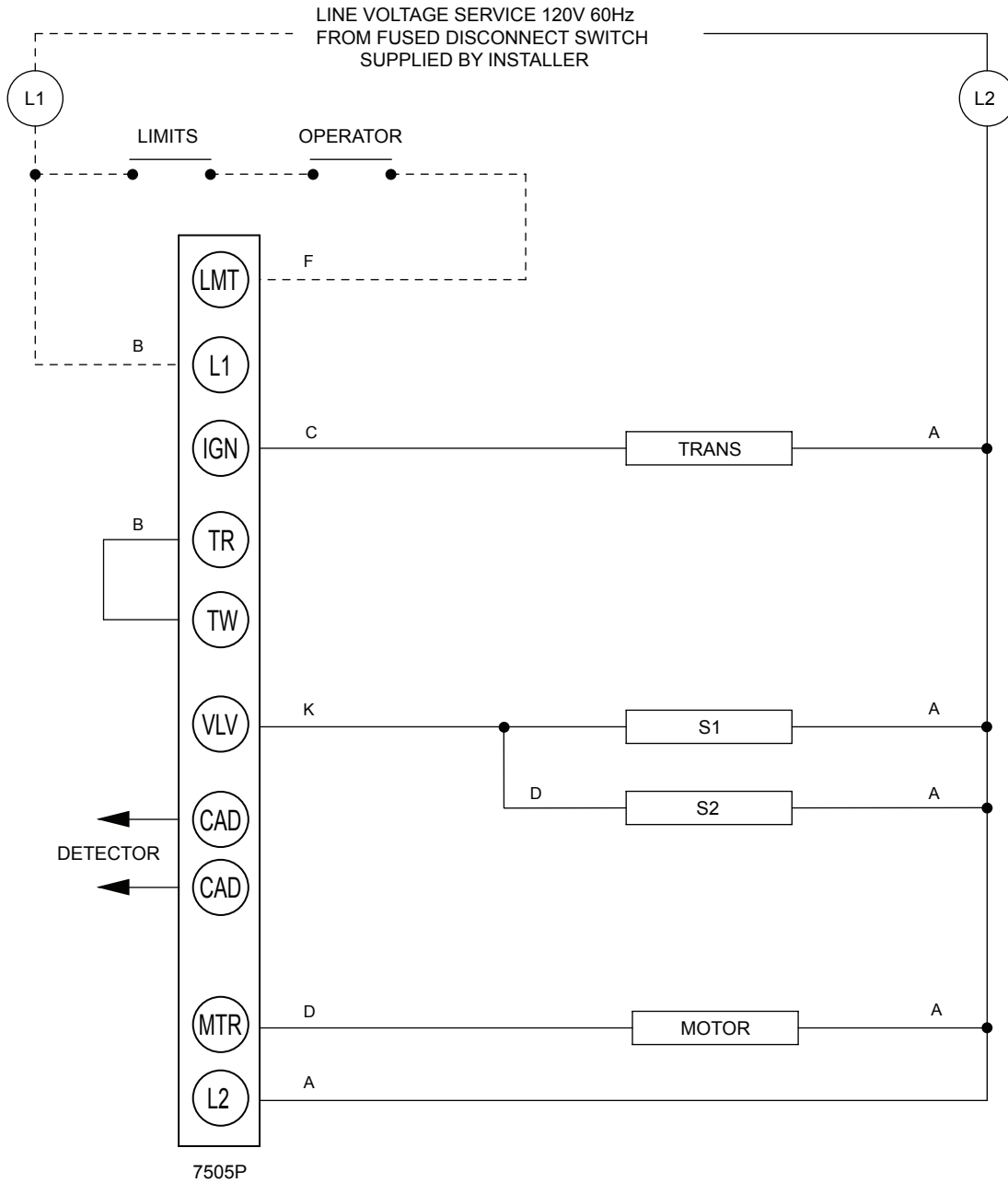

Legend

- L1** Line 1 Power (Hot)
- L2** Line 2 Power (Neutral)
- LMT** Limit control Terminal
- MTR** Motor Control Terminal
- S1** Oil Valve
- S2** Oil Valve (on Cleancut Pump)
- TRANS** Ignition Transformer
- VLV** Valve Control Terminal
- Factory Wiring
- Wiring Supplied by Installer

WARNING

Explosion, Fire, Scald, and Burn Hazard



All heating appliances must have **HIGH LIMIT** protection to interrupt electrical power and shutdown the burner if operating or safety controls fail and cause a runaway condition.

- Follow the appliance manufacturer's wiring diagrams and note all required safety controls.
- Typical safety controls include high temperature or pressure limits, low water cutoffs, pressure relief valves and blocked flue sensing switches.
- Verify all limit and safety controls are installed and functioning correctly, as specified by the manufacturer, applicable safety standards, codes and all authorities having jurisdiction.
- Ensure that the appliance is free of oil and oil vapor before starting or resetting the burner.

WARNING

Fire or Explosion Hazard



Can cause severe injury, death, or property damage.

- The control can malfunction if it gets wet, leading to accumulation of oil or explosive oil vapors.
- Never install where water can flood, drip or condense on the control.
- Never use a control that has been wet - replace it.

Figure 11 - 7505 Control



Optional Components:



Contractor's Tool:
Hand-held device for programming and diagnostics

Display Module:
Permanent device for programming and diagnostics

Alarm Module:
For adding isolated low voltage alarm contacts to the base control. See Alarm Module Instructions for specifications.



Typical Burner Sequence of Operation - 7505 Control.

Refer to the appliance manufacturer's wiring diagram for actual specifications.

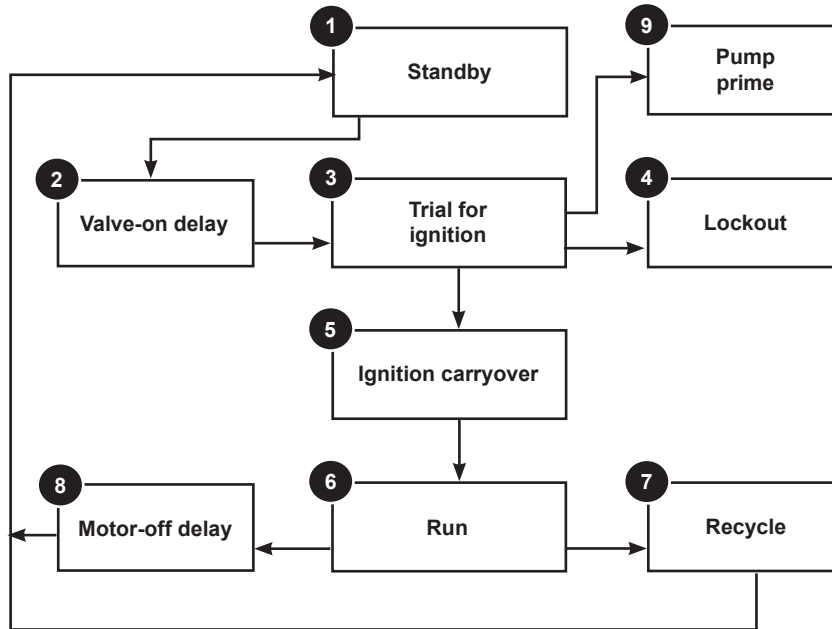

1. **Standby:** The burner is idle, waiting for a call for heat.
2. **Valve-On Delay:** The igniter and motor are on while the control delays turning on the oil solenoid valve for the programmed time.
3. **Trial For Ignition:** The oil solenoid valve is energized. A flame should be established within the factory set trial for ignition time (lockout time).
4. **Lockout:** The control has shut down for one of the following safety reasons:
 - a. The trial for ignition (lockout) time expired without flame being established.
 - b. The cad cell detected flame at the end of the Valve On Delay state.

To reset the control from lockout click the button 1-second.
5. **Ignition Carryover:** Once flame is established, the igniter remains on for 10 additional seconds to ensure flame stability.
6. **Run:** The flame is sustained until the call for heat is satisfied. The burner is then sent to Motor-Off Delay, if applicable, or it is shut down and sent to Standby.
7. **Recycle:** If the flame is lost while the burner is firing, the control shuts down the burner, enters a 60 second recycle delay, and repeats the ignition sequence. The control will continue to Recycle each time the flame is lost, until it reaches a pre-set time allotment. The control will then go into Hard Lockout instead of recycle. This feature prevents excessive accumulation of oil in the appliance firing chamber.
8. **Motor-Off Delay:** If applicable, the oil solenoid valve is turned off and the control delays turning the motor off for the set motor-off delay time before the control returns to standby.
9. **Pump Prime:** The igniter and motor are on with the oil solenoid valve energized for 4 minutes. During Pump Prime mode, the cad cell is disregarded, allowing the technician to prime the pump without having to jumper the cad cell.

NOTE: A recurrence of the above failure modes or a failed welded relay check could cause the control to enter a **Hard Lockout** state that must be reset only by a qualified service technician.

To reset from Hard Lockout, hold the reset button for 15 seconds until the yellow light turns on.

Reset Button Operation

Table 4 explains what action the control will take when the reset button is pressed for different lengths of time during the various burner operating states.

Table 4 - Reset Button Operation

If the burner is in the below state:	Pushing the reset button will:		
	Button Click (press < 1 second)	Button Hold (press > 1 second)	Button Hold (press 15+ seconds)
Lockout	Reset from Soft Lockout		Reset from Restricted (Hard) Lockout
Valve-on Delay, Trial for Ignition, Ignition Carryover	Go to Pump Prime (see <i>"Priming the Pump"</i> section in this manual.)	Disable the Burner: Any time the burner is running, press and hold the reset button to disable the burner. The burner will remain off as long as the button is held.	Enables Pump Priming: After the reset button has been held for 15 seconds, the button can then be clicked during the next ignition sequence to enter Pump Prime mode.
Run (igniter is shut off)	No action		
Motor-Off Delay, Standby	No action		
Pump Prime	No action	Exit Pump Prime mode and return to Standby	

Table 5 - Status Lights

Light Color	On Continuously	Flashing
Red	Restricted (Hard) Lockout	Soft Lockout
Green	Flame Sensed during normal operation (Could be stray light during standby)	Recycle
Yellow	Control is in Pump Prime mode or Reset button currently held for 15+ seconds.	N/A

Typical Burner Sequence of Operation - R7184P Control.

Refer to the appliance manufacturer's wiring diagram for actual specifications.

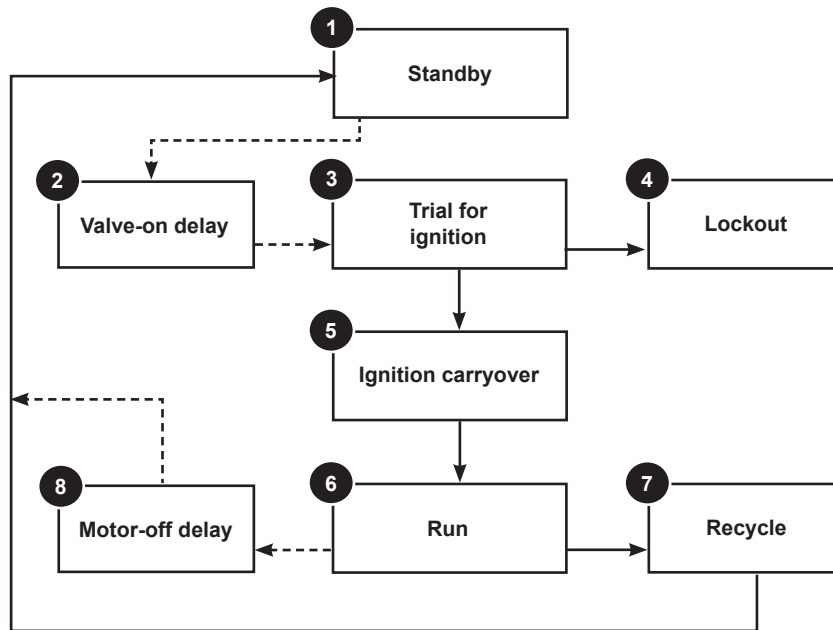

1. **STANDBY.** The burner is idle, waiting for a call for heat. When a call for heat is initiated, there is a 3-10 second delay while the control performs a safe start check.
2. **VALVE-ON DELAY.** The ignition and motor are turned on for a 15 second valve-on delay.
3. **TRIAL FOR IGNITION (TFI).** The fuel valve is opened. A flame should be established within the 15 second lockout time.
4. **LOCKOUT.** If flame is not sensed by the end of the TFI, the control shuts down on safety lockout and must be manually reset. If the control locks out three times in a row, the control enters restricted lockout.
5. **IGNITION CARRYOVER.** Once flame is established, the ignition remains on for 10 seconds to ensure flame stability before turning off. If the control is wired for intermittent duty ignition, the ignition unit stays on the entire time the motor is running.
6. **RUN.** The burner runs until the call for heat is satisfied. The burner is then sent to burner motor off delay, if applicable, or it is shut down and sent to standby.
7. **RECYCLE.** If the flame is lost while the burner is firing, the control shuts down the burner, enters a 60 second recycle delay, and then repeats the above ignition sequence. If flame is lost three times in a row, the control locks out to prevent cycling with repetitious flame loss due to poor combustion.
8. **BURNER MOTOR-OFF DELAY.** The fuel valve is closed and the burner motor is kept on for the selected motor-off delay time before the control returns the burner to standby.

Table 6 - Control System Features

Control Model	Features				
	Interrupted ignition	Limited reset, Limited recycle	Valve-on delay	Burner motor off delay	Alarm Contacts
R7505A	YES	YES	—	—	Optional
R7505B	YES	YES	YES	—	Optional
R7505P	YES	YES	YES	YES	Optional
R7184A	YES	YES	—	—	—
R7184B	YES	YES	YES	—	—
R7184P	YES	YES	YES	YES	Optional

Figure 12. - Typical wiring (R7184)

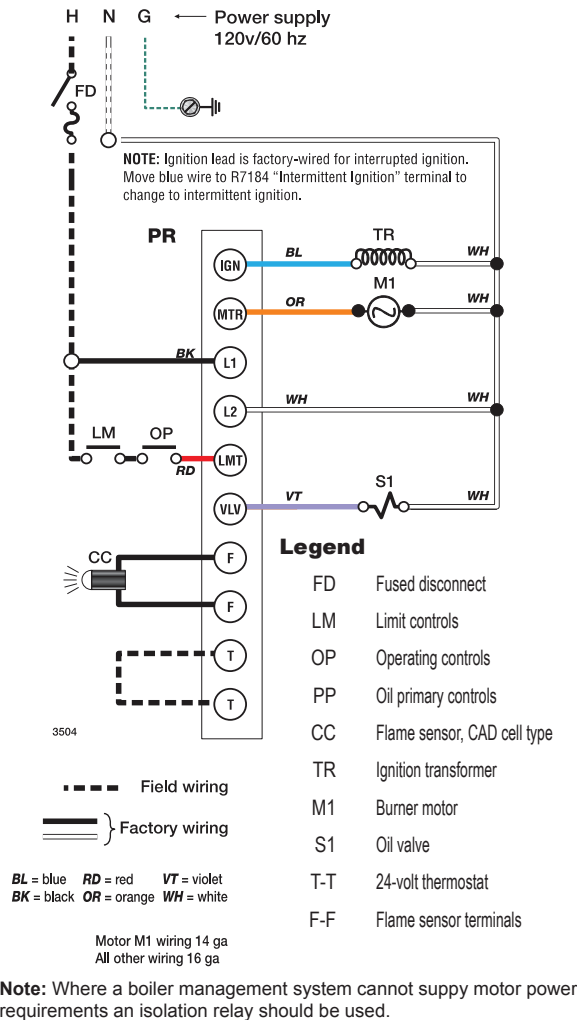

Prepare the Burner for Start-up

WARNING Do Not Bypass Safety Controls

Tampering with, or bypassing safety controls could lead to equipment malfunction and result in asphyxiation, explosion or fire.

- Safety controls are designed and installed to provide protection.
- Do not tamper with, or bypass any safety control.
- If a safety control is not functioning properly, shut off all main electrical power and fuel supply to the burner and call a qualified service agency immediately.

WARNING Professional Installation and Service Required

Incorrect installation and mishandling of start-up could lead to equipment malfunction and result in asphyxiation, explosion or fire.

- This burner must be installed and prepared for start-up by a qualified service technician who is trained and experienced in commercial oil burner system installation and operation.
- Do not attempt to start the burner unless you are fully qualified.
- Do not continue with this procedure until all items in the "Prepare the burner for start-up" section have been verified.
- Carefully follow the wiring diagrams, control instruction sheets, flame safeguard sequence of operation, test procedures and all appliance manufacturer's directions that pertain to this installation.
- If any of these items are not clear or are unavailable, call Beckett at 1-800-645-2876 for assistance.

CAUTION Keep Service Access Covers Securely Installed

These covers must be securely in place to prevent electrical shock, damage from external elements, and protect against injury from moving parts.

- All covers or service access plates must be in place at all times except during maintenance and service.
- This applies to all controls, panels, enclosures, switches, and guards or any component with a cover as part of its design.

Start-up checklist - Verify the following before attempting to start burner.

- Combustion air supply and venting have been inspected and verified to be free of obstructions and installed in accordance with all applicable codes.
- Oil nozzle has been selected correctly and securely installed in the nozzle adapter.
- Fuel unit by-pass plug **has not** been installed for one-pipe oil system.
- By-pass plug **has been** installed for two-pipe oil system.

- Fuel connection to nozzle line assembly is secure.
- Dimension Z has been set per the ‘Set Z Dimension’ instructions detailed earlier in this manual. The acorn nut (**Figure 7**, item **C**) should never be loosened once the Z dimension is initially set.
- Fuel supply line is correctly installed, the oil tank is sufficiently filled, and shut-off valves are open.
- Burner is securely mounted in appliance, with pressure firing plate and gasket installed for pressurized chamber application.
- Appliance has been filled with water (boilers) and controls have been operationally checked.
- Burner has been installed in accordance with appliance manufacturer’s instructions (when available).
- Also refer to appliance manufacturer’s instructions (when available) for start-up procedures.
- Initial head position (**Figure 7**)
 - The indicator plate assembly markings correspond to head position settings.
 - Loosen the fastener (**Figure 7**, item **d**) and slide the indicator plate until the number on the indicator plate corresponds to the initial head setting listed in **Table 7**, for the desired firing rate.
 - When the head position has been set, tighten the fastener and the spline nut.

Table 7 - Initial indicator adjustment plate settings (head position)

Rate GPH	Approximate head settings		
	CF500	CF800	
		Tube A	Tube B
1.75	0	--	--
2.25	0		
3.00	4	0	--
3.50	5	1	--
4.00	5	2	--
5.00	6	4	3
5.50	6	4	4
6.00	--	4	4
7.00	--	6	5
8.00	--	--	6

Initial air settings (**Table 8**)

- Loosen the air band and shutter, and adjust to the approximate firing rate settings given in **Table 8**.
- These initial settings should be adequate for starting the burner. Once the burner is in operation, the air settings will be adjusted for best performance as discussed later in this manual.
- Follow the procedures described later in this manual for fine-tuning the air settings.

Table 8 - Initial air shutter and band settings

Rate GPH	Approximate air settings					
	CF500		CF800			
			Tube A		Tube B	
	Shutter	Band	Shutter	Band	Shutter	Band
1.75	1	0	--	--	--	--
2.25	2	0	--	--	--	--
3.00	10	1	1	0	--	--
3.50	10	2	3	0	--	--
4.00	10	3	4	0	--	--
5.00	10	5	9	0	8	2
5.50	10	10	9	5	9	4
6.00	--	--	10	3	10	3
7.00	--	--	10	8	10	5
8.00	--	--	--	--	10	10

Note: These settings are approximate, and can vary depending on actual job conditions and overfire pressure

Set appliance limit controls

Set the appliance limit controls in accordance with the appliance manufacturer’s recommendations.

Prepare the fuel unit for air venting

- To vent air from the oil supply line, attach a clear hose to the pump air bleed valve (**Figures 8 & 9**) on the fuel unit. Provide a container to catch the oil. Loosen the pump air bleed valve.
- Vent the air as described in the next section under **Start the burner**.

Start the Burner

WARNING Explosion and Fire Hazard

Failure to follow these instructions could lead to equipment malfunction and result in heavy smoke emission, soot-up, hot gas puff-back, fire and asphyxiation hazards.

- Do not attempt to start the burner when excess oil has accumulated in the appliance, the appliance is full of vapor, or when the combustion chamber is very hot.
- Do not attempt to re-establish flame with the burner running if the flame becomes extinguished during start-up, venting, or adjustment.
- **Vapor-Filled Appliance:** Allow the unit to cool off and all vapors to dissipate before attempting another start.
- **Oil-Flooded Appliance:** Shut off the electrical power and the oil supply to the burner and then clear all accumulated oil before continuing.
- If the condition still appears unsafe, contact the Fire Department. Carefully follow their directions.
- Keep a fire extinguisher nearby and ready for use.

Starting the burner and venting air

Priming the pump

WARNING Hot Gas Puff-back and Heavy Smoke Hazard



Failure to bleed the pump properly could result in unstable combustion, hot gas puff-back and heavy smoke.

- Do not allow oil to intermittently spray into a hot combustion chamber while bleeding.
- Install a gauge in the nozzle discharge port tubing or fully open the pump bleed valve to prevent oil spray from accumulating in the combustion chamber when venting air from the fuel pump.
- Ensure that all bubbles and froth are purged from the oil supply system before tightening the pump air bleed valve.

- Priming the Pump For 7505 Control:

- Initiate a call for heat.
- After the burner starts, press and hold the reset button for 15 seconds until the yellow light turns on. This indicates that the button has been held long enough.
- Release the reset button. The yellow light will turn off and the burner will start up again.
- At burner start up, click the reset button while the igniter is still on. This will transition the control to a dedicated Pump Prime mode, during which the motor, igniter, and valve are powered for four minutes. The yellow light will be on.
- Bleed the pump until all froth and bubbles are purged. If desired, terminate the call for heat or hold the reset button for at least one second to exit Pump Prime mode and return to Standby.
- At the end of 4 minutes, the yellow light will turn off and the control will automatically return to standby mode.
- If prime is not established during the four minute pump prime mode, start the burner and click the reset button to re-enter Pump Prime mode. Repeat the priming procedure until the pump is fully primed and the oil is free of bubbles.
- Terminate the call for heat, and the control will resume normal operation.

- Priming the Pump For 7184 Control:

- Initiate a call for heat
- While the ignition is on, press and release the reset button on the control (hold 1/2 second or less). If the control has not locked out since it's most recent complete heat cycle, the lockout time will be extended to 4 minutes (45 seconds in earlier units), and the ignition will remain on the entire heat cycle.
- Bleed the pump until all froth and bubbles are purged. If prime is not established within the extended lockout time, the control will lock out. Press the reset button to reset the control and return to the functions listed in the previous step.
- Repeat the previous steps if needed, until the pump is fully primed and the oil is free of bubbles. Then terminate the call for heat, and the control will resume normal operation.

Disable function

Any time the motor is running, press and hold the reset button to disable the burner. The burner will remain off as long as the button is held and will return to standby when released.

Cad Cell Resistance Measurement

- If the Beckett 7505 control is equipped with the GeniSys Display Module, part 52067U, the cad cell resistance can be selected and read on the LCD screen. Also, the GeniSys Contractor Tool, part 52082U, can be used for this purpose.
- If these are not available, the cad cell leads can be unplugged from the control and the resistance measured with a meter in the conventional way. Conduct these tests with flame present.

Flame Detection Range
Normal = 0 to 1600 ohms
Limited = 1600 ohms to lockout

Resetting From Restricted or Hard Lockout

- If the control continues to lockout without a satisfied call for heat, or fails the motor relay check, the control enters Hard (restricted) Lockout in order to limit accumulation of unburned oil in the combustion chamber
- To reset 7505, hold the button down for 15 seconds until the red light turns off and the yellow light turns on.
- To reset R7184 control hold reset button down for 30 seconds until the LED flashes once for one second.

Set combustion using instruments

1. Allow the burner to run for approximately 5 to 10 minutes.
2. Set the stack or over-fire draft to the level specified by the appliance manufacturer.
 - **Natural Draft Applications;** typically over-fire draft is -0.01" or -0.02" w.c.
 - **Direct Venting;** typically may not require draft adjustment.
 - **High Efficiency/Positive Pressure Appliances;** also vary from traditional appliances (see manufacturer's recommendations).

3. Follow these four steps to properly adjust the burner:

Step 1: Adjust the air shutter/band until a trace of smoke is achieved.

Step 2: At the trace of smoke level, measure the CO₂ (or O₂). This is the vital reference point for further adjustments. Example: 13.5% CO₂ (2.6% O₂)

Step 3: Increase the air to reduce the CO₂ by 1.5 to 2 percentage points. (O₂ will be increased by approximately 2.0 to 2.7 percentage points.) Example: Reduce CO₂ from 13.5% to 11.5% (2.6% to 5.3% O₂).

Step 4: Recheck smoke level. It should be Zero. This procedure provides a margin of reserve air to accommodate variable conditions.

If the draft level has changed, recheck the smoke and CO₂ (or O₂) levels and readjust the burner, if necessary

4. Once combustion is set, tighten all fasteners on air band, air shutter and escutcheon plate.
5. Start and stop the burner several times to ensure satisfactory operation. Test the primary control and all other appliance safety controls to verify that they function according to the manufacturer's specifications.
6. Check the breech draft pressure against the appliance manufacturer's recommended setting (typically + 0.1" W.C.). If the breech pressure is higher or lower than recommended level, adjust the appliance breech damper to achieve the specified setting. Recheck the smoke and CO₂ (or O₂) levels. Adjust burner air if necessary.

Maintenance and Service



WARNING

Annual Professional Service Required



Tampering with or making incorrect adjustments could lead to equipment malfunction and result in asphyxiation, explosion or fire.

- DO NOT TAMPER WITH THE UNIT OR CONTROLS - CALL YOUR SERVICE PERSONNEL.
- To ensure continued reliable operation, a qualified service technician must service this burner annually.
- More frequent service intervals may be required in dusty or adverse environments.
- Operation and adjustment of the burner requires technical training and skillful use of combustion test instruments and other test equipment.



Always keep the fuel oil supply valve shut off if the burner(s) is shut down for an extended period of time.

Annual Service — by qualified service technician

Have the burner inspected, tested and started at least annually by a qualified service technician. This annual test/inspection should include at least the following:

- Replace the oil supply line filter. The line filter cartridge must be replaced to avoid contamination of the fuel unit and nozzle.
- Inspect the oil supply system. All fittings should be leak-tight. The supply lines should be free of water, sludge and other restrictions.
- Remove and clean the pump strainer if applicable.
- Replace the nozzle with the exact brand, pattern, gph, flow rate and spray angle.
- Clean and inspect the electrodes for damage, replacing any that are cracked or chipped.
- Check electrode tip settings. Replace electrodes if tips are rounded.

- Inspect the igniter spring contacts.
- Clean the cad cell lens surface, if necessary.
- Inspect all gaskets. Replace any that are damaged or would fail to seal adequately.
- Inspect the combustion head and air tube. Remove any carbon or foreign matter. Replace all damaged units with exact parts.
- Clean the blower wheel, air inlet, air guide, burner housing and static plate of any lint or foreign material.
- If motor is not permanently lubricated, oil motor with a few drops of SAE 20 nondetergent oil at each oil hole. DO NOT over oil motor. Excessive oiling can cause motor failure.
- Check motor current. The amp draw should not exceed the nameplate rating.
- Check all wiring for secure connections or insulation breaks.
- Check the pump pressure and cutoff function.
- Check primary control safety lockout timing.
- Check ignition system for proper operation.
- Inspect the vent system and chimney for soot accumulation or other restriction.
- Clean all the passages and flue pipe. Replace corroded or damaged pipes.
- Clean the appliance thoroughly according to the manufacturer's recommendations.
- Check the burner performance. Refer to the section "Set combustion with test instruments".
- It is good practice to make a record of the service performed and the combustion test results.

Monthly Maintenance — by owner

- Observe combustion air openings and vent system for integrity. Openings must be clean and free of obstructions.
- Check oil lines and fittings to verify there are no leaks.
- Observe burner ignition and performance to verify smooth operation.
- Shut the system down if you observe abnormal or questionable operation. Call a qualified service agency for professional inspection and service.

Replacement parts

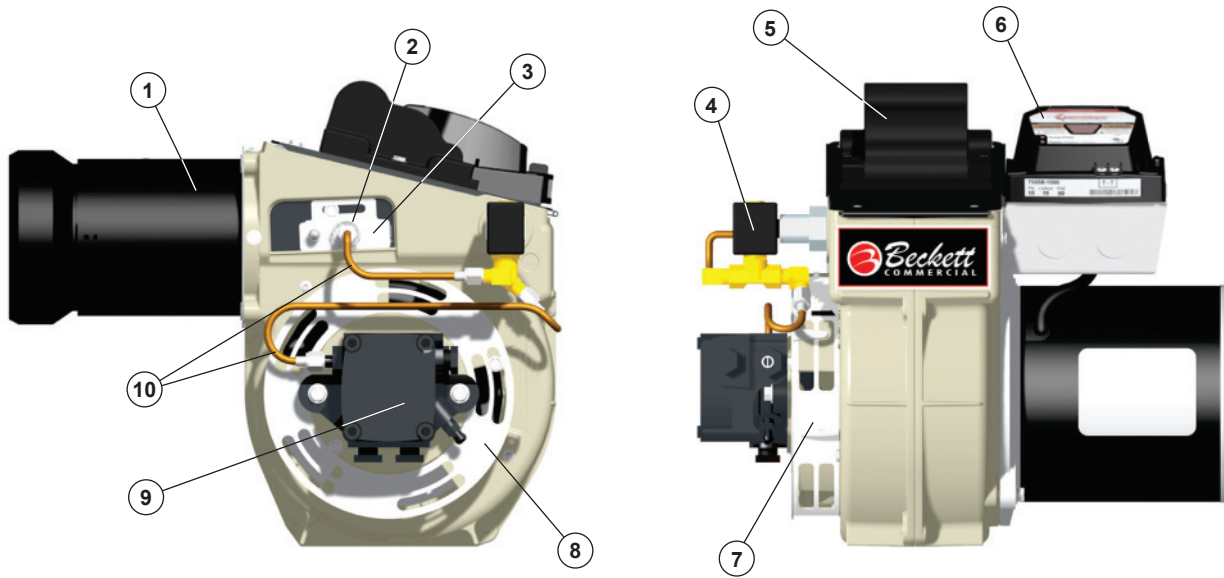
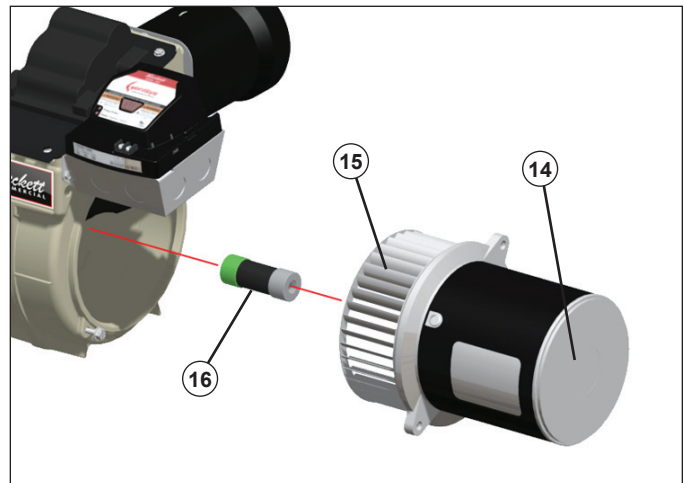
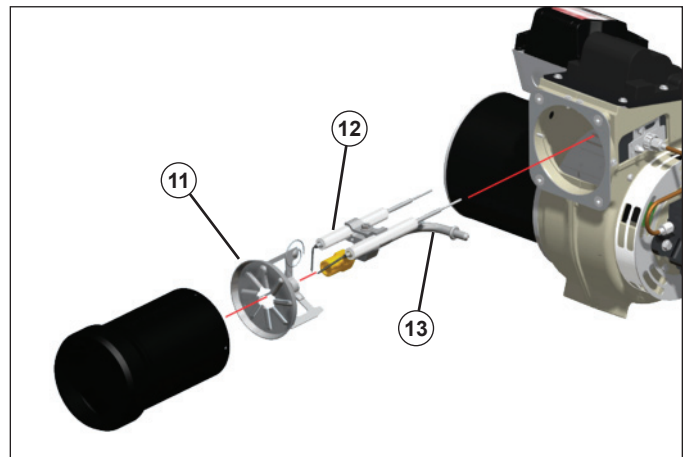
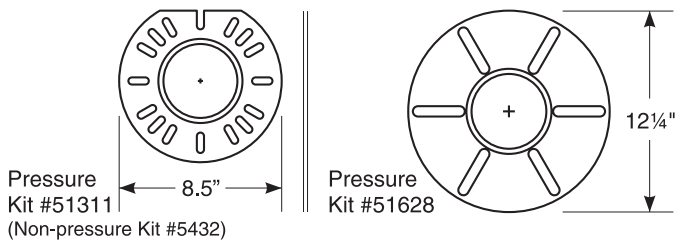

Figure 13 - Adjustable mounting plates for CF500 and CF800



Parts List

Item	Part Name/Description	Part Number
1	Air Tube	Specify
2	Spline Nut	3666
3	Adjusting plate assembly	51286U
4	Blocking Oil Solenoid Valve	2182602U
5	Igniter	51824U
6	Control	Specify
7	Air Band	3819
8	Air Shutter	3215
9	Fuel Pump	Specify
10	Fuel lines	Specify Lengths
11	Head Assembly: CF500 - KK CF800 - KH (Tube A) CF800 - KJ (Tube B)	51401U 51252P 51302P
12	Electrode Assembly	Specify
13	Nozzle Line Assembly	Specify
14	Motor - 1/3 PSC	21341U
15	Blower Wheel: CF500 - 5-19/32" x 2-13/32" CF800 - 6-5/16" x 2-3/8"	21448U 21339U
16	Coupling	2433
17	Flange Kit	See Figure 13
18	Pedestal Kit	Not Shown

Limited Warranty Information

The R. W. BECKETT CORPORATION ("Beckett") warrants to persons who purchase its "Products" from Beckett for resale, or for incorporation into a product for resale ("Customers"), that its equipment is free from defects in material and workmanship. To qualify for warranty benefits, products must be installed by a qualified service agency in full compliance with all codes and authorities having jurisdiction, and used within the tolerances of Beckett's defined product specifications.

To review the complete warranty policy and duration of coverage for a specific product, or obtain a written copy of warranty form 61545, please choose one of the following options:

1. Visit our website at: www.beckettcorp.com/warranty
2. Email your request to: rwb-customer-service@beckettcorp.com
3. Write to: R. W. Beckett Corporation, P. O. Box 1289, Elyria, OH 44036

NOTE: Beckett is not responsible for any labor cost for removal and replacement of equipment.

THIS WARRANTY IS LIMITED TO THE PRECISE TERMS SET FORTH ABOVE, AND PROVIDES EXCLUSIVE REMEDIES EXPRESSLY IN LIEU OF ALL OTHER REMEDIES, AND IN PARTICULAR THERE SHALL BE EXCLUDED THE IMPLIED WARRANTIES OF MERCHANTABILITY AND FITNESS FOR A PARTICULAR PURPOSE. IN NO EVENT WILL BECKETT BE LIABLE FOR ANY INCIDENTAL OR CONSEQUENTIAL DAMAGE OF ANY NATURE. Beckett neither assumes, nor authorizes any person to assume for Beckett, any other liability or obligation in connection with the sale of this equipment. Beckett's liability and Customer's exclusive remedy is limited to the cost of the product.



USA: P.O. Box 1289 • Elyria, Ohio 44036

Canada: R.W. Beckett Canada, Ltd. • Unit #3, 430 Laird Road • Guelph, Ontario N1G 3X7
www.beckettcorp.com